



APR 04 1983

Industrial Sewing Machine Parts Catalog

Model 166R
166RB
167R
167RB

INDEX	Page
Arm bed & its accessories	1
Thread take-up lever & needle bar mechanism	3
Arm shaft & vertical shaft mechanism	5
Stitch length regulator mechanism	7
Presser foot mechanism	9
Upper feed mechanism	11
Lower feed mechanism	15
Hook shaft & rotating hook mechanism	17
Oil lubrication mechanism	19
Accessory box & accessories	21
Oil pan & other accessories	23

ARM BED & ITS ACCESSORIES

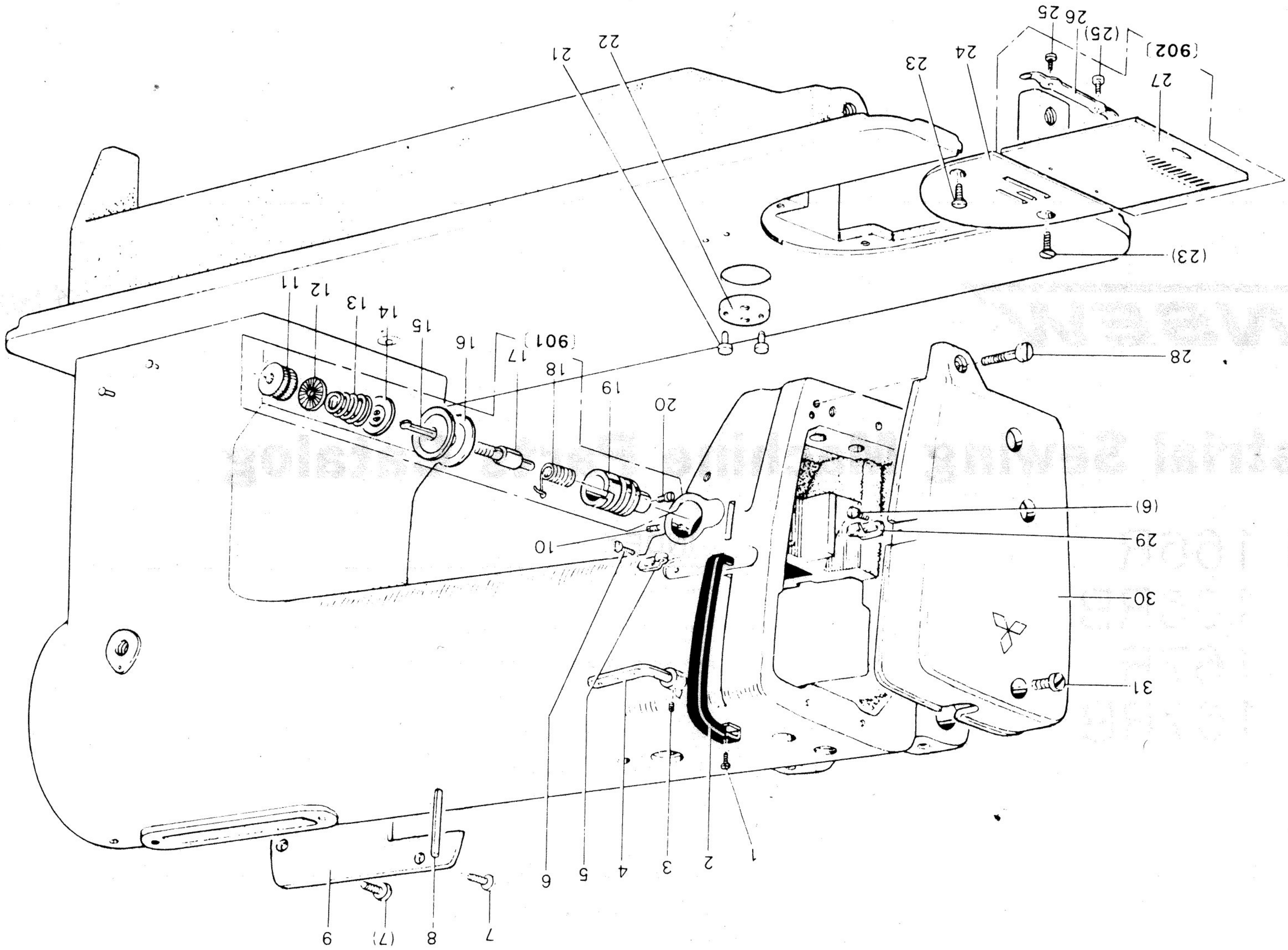

ARM BED & ITS ACCESSORIES

Fig No.				Description	Amt Req	Common Parts														
						167R	167RB	166R	166RB											
1	M9	1107	002	W500092H01	Screw 11/64(40)×5.5	1	○	○	○	○										
2	MF	10A0	584	W468291H01	Thread take-up cover	1	○	○	○	○										
	MF	17B0	584	W458150H01	Thread take-up cover	1	○	○	○	○										
3	M9	1108	001	B 503846H01	Set screw 11/64(40)×5.5	1	○	○	○	○										
4	MF	10A0	180	B 409034H01	Three hole thread guide	1	○	○	○	○										
5	MF	80A0	181	W483484H01	Thread guide for arm	1	○	○	○	○										
	MG	43A0	181	W487126H01	Thread guide for arm	1	○	○	○	○										
6	M9	0909	003	W501901H01	Screw 9/64(40)×6	2	○	○	○	○										
7	M9	1128	003	W500511H01	Screw 11/64(40)×7	4	○	○	○	○										
8	MF	10A0	186	W461744H01	Spool pin	1	○	○	○	○										
9	MG	30B0	880	W488418H01	Arm side cover	1	○	○	○	○										
10	M9	1508	001	B 509088H01	Set screw 15/64(28)×8	1	○	○	○	○										
11	M9	1608	046	W476469H01	Thread tension regulating thumb nut 1/4(40)	1	○	○	○	○										
12	MT	60A0	802	W476470H01	Thumb nut revolution stopper	1	○	○	○	○										
13	MF	43C0	245	W478173H01	Thread tension spring	1	○	○	○	○										
14	MM	11A0	556	W477611H01	Thread tension releasing disc	1	○	○	○	○										
15	M9	0204	060	B 509216H01	Thread tension releasing pin φ2×28.4	1	○	○	○	○										
16	MF	10A0	555	W444059H01	Thread tension disc	2	○	○	○	○										
17	MF	10A0	553	B 419178H01	Thread tension stud	1	○	○	○	○										
18	MF	83A0	187	W486346H02	Thread take-up spring	1	○	○	○	○										
19	MF	10A0	709	W453140H01	Thread tension regulator bushing	1	○	○	○	○										
20	M9	0901	002	W500741H01	Screw 9/64(40)×4	1	○	○	○	○										
901	MF	43E0	210	W331008G03	Thread tension regulator complete	1	○	○	○	○										
21	M9	1107	002	W500092H01	Screw 11/64(40)×5.5	2	○	○	○	○										
22	MG	30A0	601	W483491H01	Cloth guide plate	1	○	○	○	○										
23	M9	1106	011	W502948H01	Screw 11/64(40)×8	2	○	○	○	○										
24	MF	26B0	101	W322721H01	Needle plate B2.6(7mm)	1	○	○	○	○										
25	M9	0604	002	B 509070H01	Screw 3/32(56)×2.2	2	○	○	○	○										
26	MF	10A0	471	B 419207H01	Spring for slide plate	1	○	○	○	○										
27	MG	30A0	470	B 419208H02	Slide plate	1	○	○	○	○										
902	MF	80E0	470	W461757G02	Slide plate complete	1	○	○	○	○										
28	M9	1106	003	W500369H01	Screw 11/64(40)×20	1	○	○	○	○										
29	MF	10A0	181	W452151H01	Thread guide for face Plate	1	○	○	○	○										
	MG	43A1	181	W487127H01	Thread guide for face Plate	1	○	○	○	○										
30	MG	30A1	830	W344935H01	Face plate	1	○	○	○	○										
31	M9	1070	003	S 516131H01	Screw 5/32(40)×30	1	○	○	○	○										

THREAD TAKE-UP LEVER & NEEDLE BAR MECHANISM

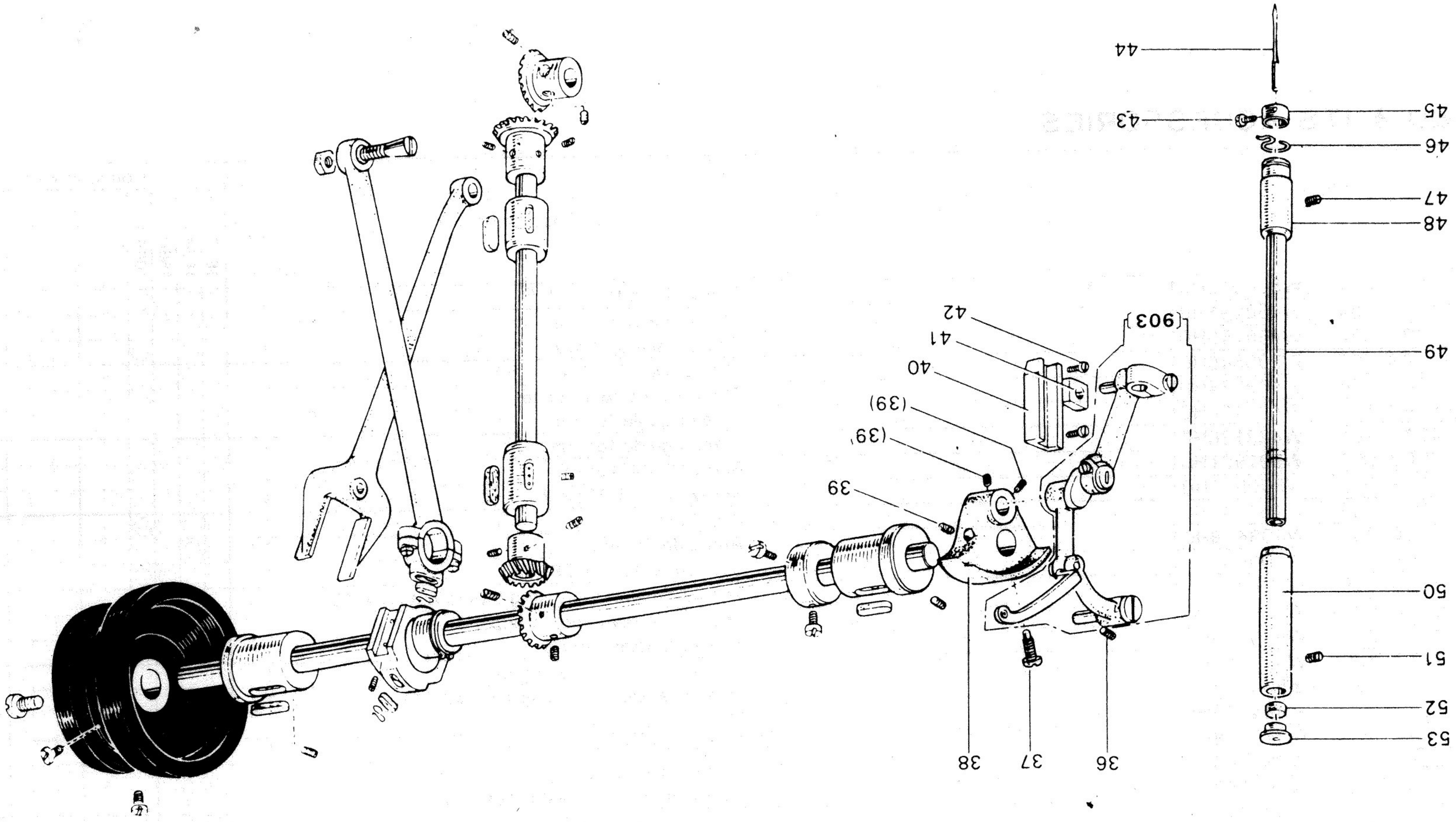

ARM SHAFT & VERTICAL SHAFT MECHANISM

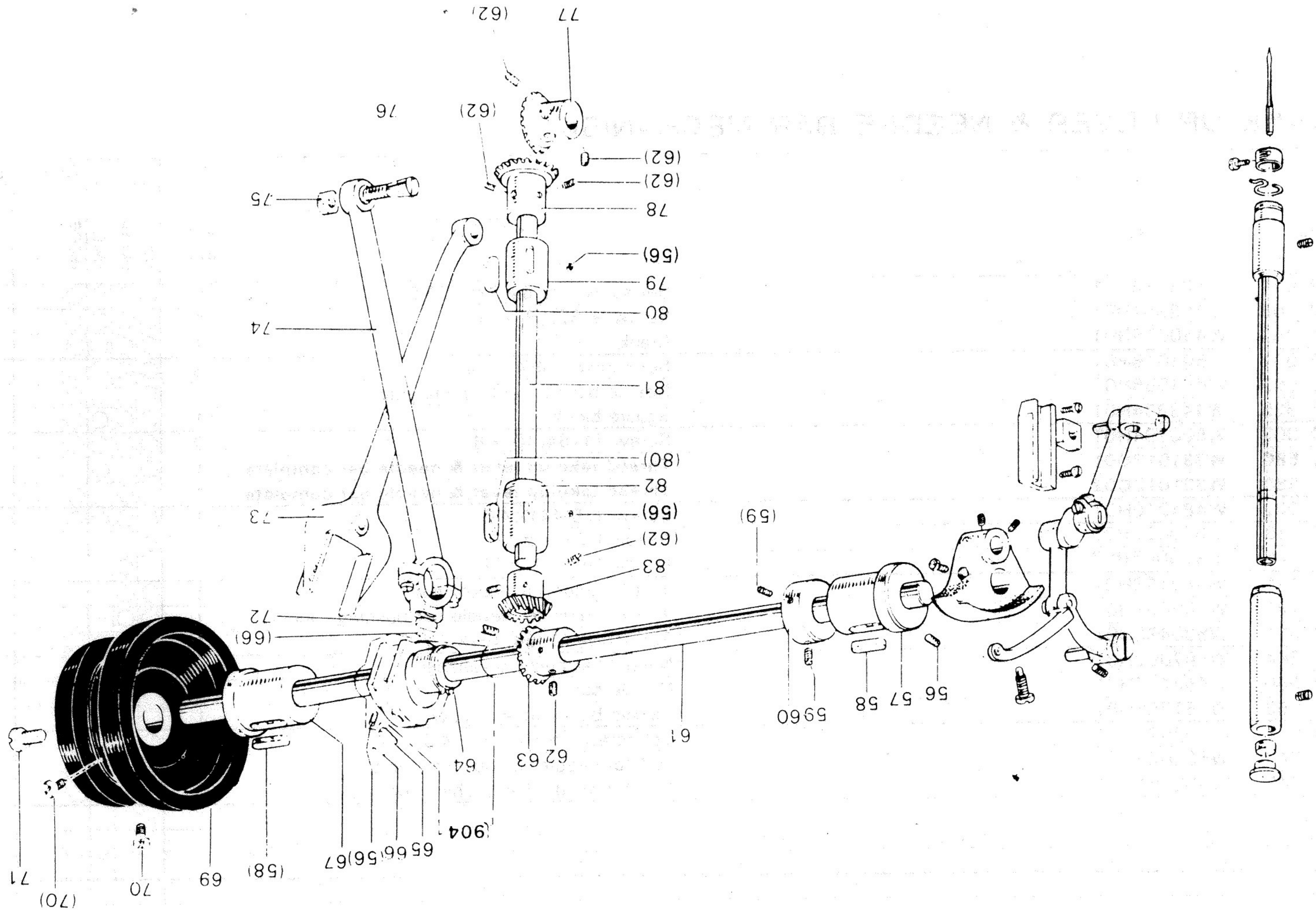

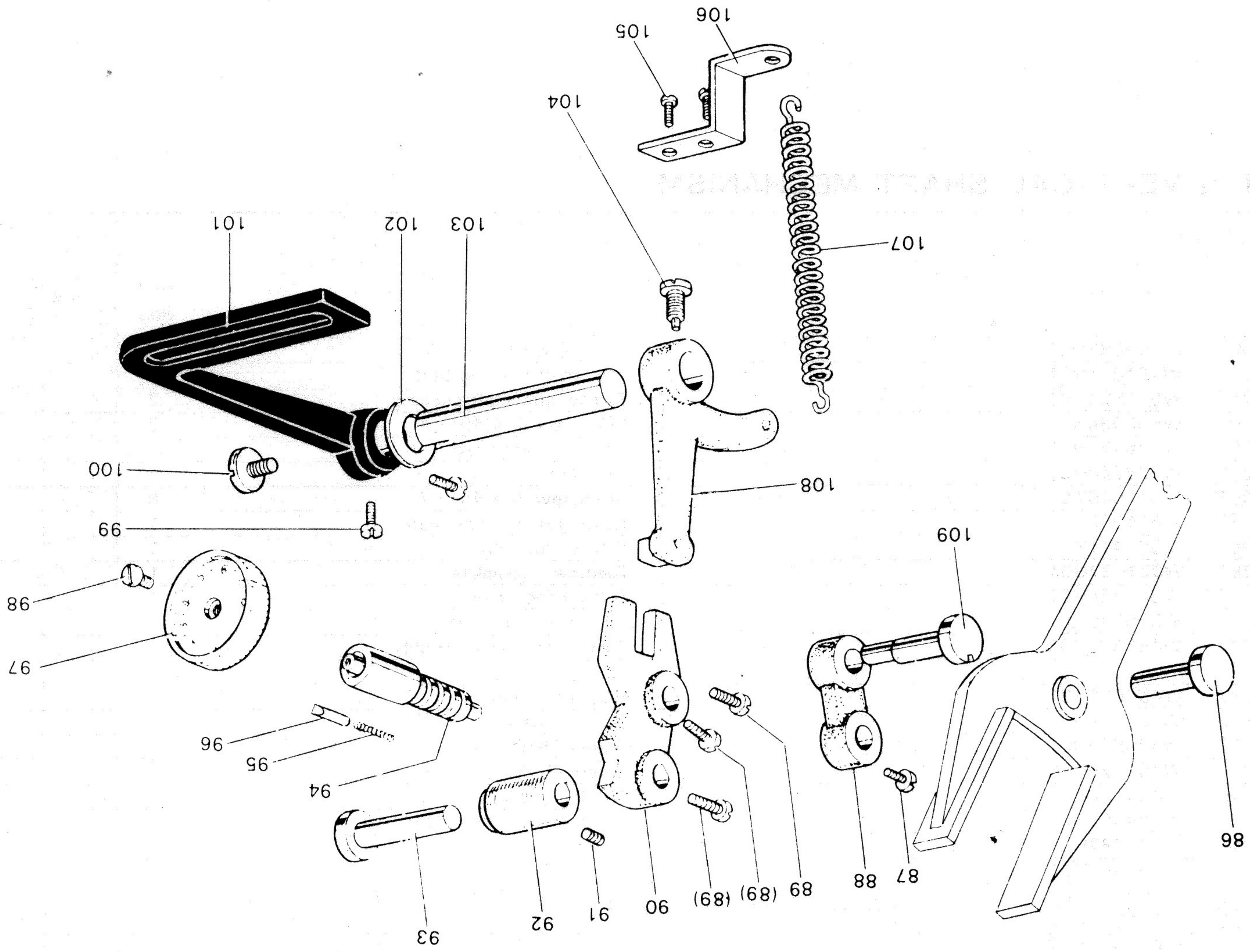

STITCH LENGTH REGULATOR MECHANISM

STITCH LENGTH REGULATOR MECHANISM

Fig.	No.	Parts No.	Ref. No.	Description	Amt. Req.	Common Parts			
						167R	167RB	166R	166RB
	86	M9 0718 063	W481425H01	Set pin	1	○	○	○	○
	87	M9 1501 002	W502945H02	Screw 15/64(28)×8.5	1	○	○	○	○
	88	MG 30A0 153	W483492H01	Feed connecting link	1	○	○		
	89	M9 1504 002	B 508963H01	Screw 15/64(28)×10	3	○	○	○	○
	90	MG 30A0 152	W487005H01	Feed regulator	1	○	○		
	91	M9 1513 001	B 509060H01	Set screw 15/64(28)×10	1	○	○	○	○
	92	MG 41B0 750	W479396H01	Feed connecting bushing	1	○	○	○	○
	93	M9 0904 063	W479395H01	Feed connecting hinge pin	1	○	○	○	○
	94	MF 60A1 640	W484899H01	Stitch length regulator screw	1	○	○		
	95	MG 42A0 572	W487125H01	Presser spring for stitch length	1	○	○		
	96	M9 0420 060	W487124H01	Stopper pin for stitch length 4×18	1	○	○		
	97	MG 42A0 631	W344970H01	Stitch length regulator dial	1	○	○		
	98	M9 1209 002	B 503887H01	Screw 3/16(28)×8	1	○	○	○	○
	99	M9 1501 002	W502945H01	Screw 15/64(28)×8.5	2	○	○	○	○
	100	M9 1207 003	B 509288H01	Screw 3/16(28)×6.5	1	○	○	○	○
	101	MF 26B0 632	W346067H01	Reverse sewing lever	1	○	○		
	102	M9 5003 053	B 503895H01	Spring washer	1	○	○	○	○
	103	MF 60A0 633	W462608H01	Reverse stitch lever shaft	1	○	○	○	○
	104	M9 1501 007	B 509256H01	Screw 15/64(28)×14.5	1	○	○	○	○
	105	M9 1110 002	W500294H01	Screw 11/64(40)×8	2	○	○	○	○
	106	MG 30B0 708	W462888H01	Feed regulating spring holder	1	○	○	○	○
	107	MF 60A0 572	W445312H01	Spring	1	○	○	○	○
	108	MG 41E1 635	W331018G02	Stitch length regulating bracket complete	1	○	○		
	109	MG 30A0 761	W487006H01	Eccentric pin	1	○	○		

PRESSER FOOT MECHANISM

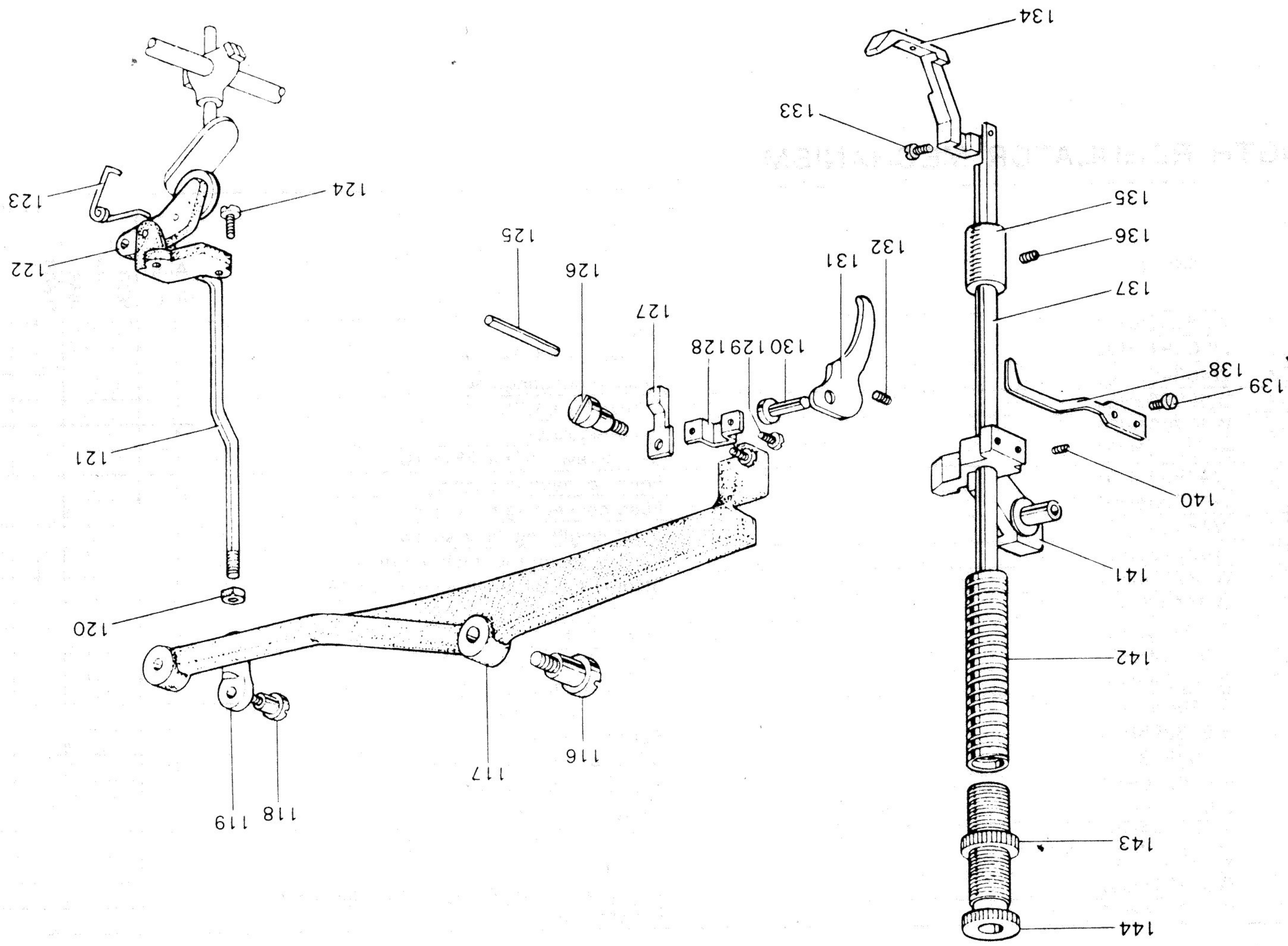

PRESSER FOOT MECHANISM

Fig. No.	Parts No.	Ref. No.	Description	Amt. Req.	Common Parts																
					167R	167RB	168R	166RB													
116	M9 2001 016	B 503843H01	Hinged screw 5/16(24)×30	1	○	○															
117	MG 30A0 725	W344931H01	Lifting lever (upper)	1	○	○															
118	M9 1505 016	B 509176H01	Hinged screw 15/64(28)×10	1	○	○	○	○													
119	MF 60A0 591	W462748H01	Knee lifter rock shaft arm	1	○	○	○	○													
120	M9 1251 045	B 509177H01	Nut 3/16(32)	1	○	○	○	○													
121	MG 30B0 593	W461082H01	Lifting lever connecting rod	1	○	○	○	○													
122	MG 30E1 594	W482314G01	Knee lifter bell crank complete	1	○	○															
123	MG 30B1 729	W464022H02	Knee lifter bell crank spring	1	○	○	○	○													
124	M9 1104 003	B 509264H01	Screw 11/64(40)×12	2	○	○	○	○													
125	M9 0414 060	W502957H03	Upper thread releasing pin	1	○	○	○	○													
126	M9 1223 015	W487004H01	Hinged screw 3/16(28)×6.2	1	○	○															
127	MG 30B1 222	W483465H01	Upper thread releasing cam	1	○	○															
128	MG 30A0 154	W483466H01	Guide plate	1	○	○															
129	M9 1109 002	W500511H01	Screw 11/64(40)×7	2	○	○															
130	M9 0704 063	B 503977H01	Presser foot lifting pin	1	○	○	○	○													
131	MF 60A0 252	W443698H01	Presser lifter	1	○	○	○	○													
132	M9 1109 001	B 509339H01	Set screw 11/64(40)×8.5	1	○	○	○	○													
133	M9 0922 002	W464016H01	Screw 9/64(40)×8	1	○	○	○	○													
134	MG 10B0 256	W464028H01	Presser foot (inside)	1	○	○	○	○													
135	MG 30B0 267	W462887H01	Presser bar bushing (under)	1	○	○	○	○													
136	M9 1102 001	W500489H01	Set screw 11/64(40)×2.7	2	○	○	○	○													
137	MF 60A0 262	W444011H01	Presser bar	1	○	○	○	○													
138	MN 30A0 216	W502468H01	Thread guide	1	○	○															
139	M9 1107 002	W500092H01	Screw 11/64(40)×5.5	1	○	○															
140	M9 1508 001	B 509088H01	Set screw 15/64(28)×8	1	○	○	○	○													
141	MG 10B0 265	W453535H01	Presser bar holder	1	○	○															
142	MF 60A0 259	W461782H01	Presser bar spring	1	○	○	○	○													
143	M9 3201 045	W471438H01	Special nut 1/2(28)	1	○	○	○	○													
144	M9 3201 035	B 409037H02	Presser regulating thumb screw 1/2(28)×43	1	○	○	○	○													

UPPER FEED MECHANISM

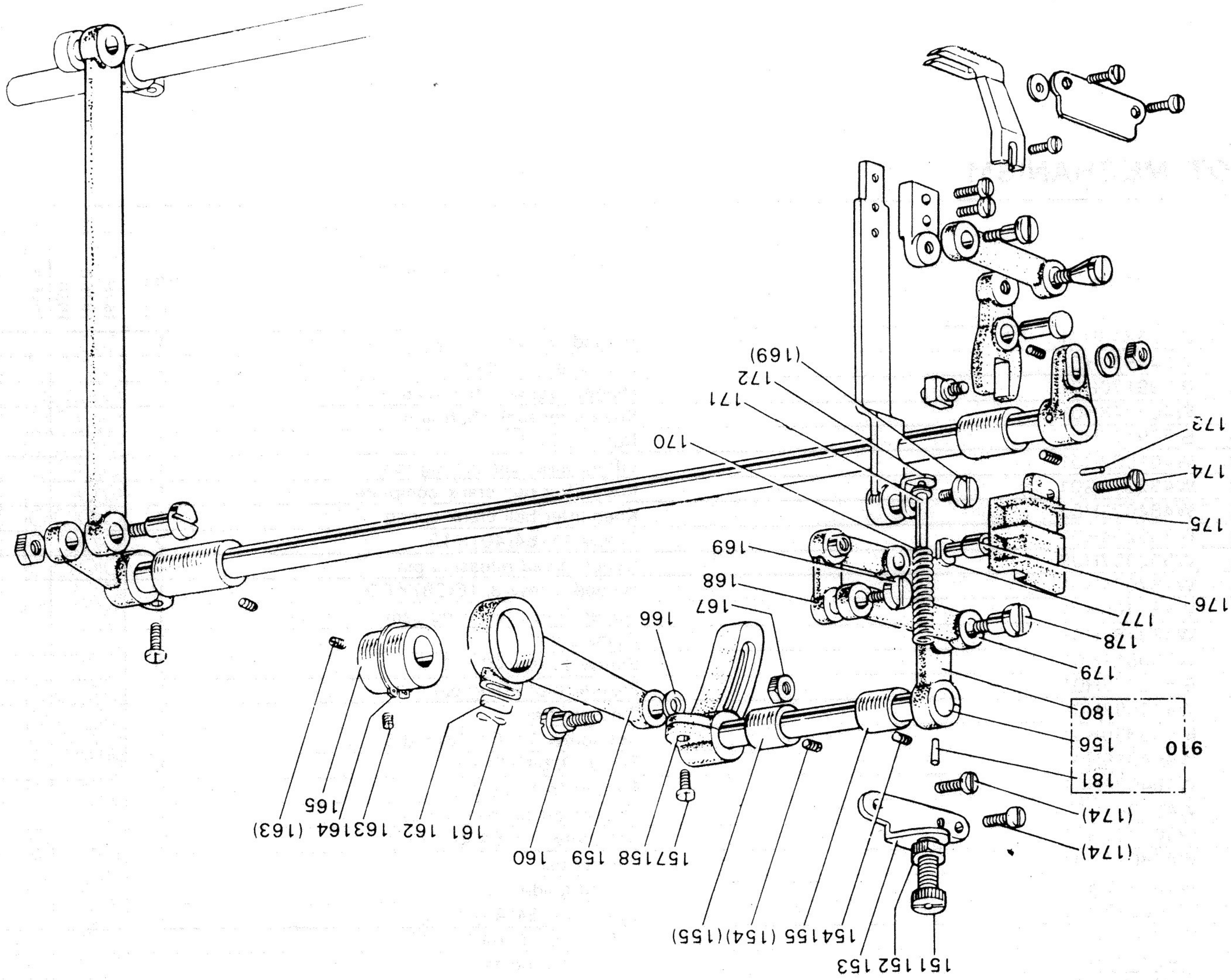

UPPER FEED MECHANISM

No.	Parts. No.	Ref. No.	Description	Amt. Req.	Common Parts									
					167R	167RB	166R	166RB						
151	M9 1801 035	W502411H01	Feed regulating screw 9/32(28)×35	1	○	○	○	○						
152	M9 1801 045	W500009H01	Nut 9/32(28)	1	○	○	○	○						
153	MG 30B1 261	W480473H01	Presser regulating bracket	1	○	○	○	○						
154	M9 1108 001	B 503846H01	Set screw 11/64(40)×5.5	2	○	○	○	○						
155	MG 30A0 833	W483458H02	Feed lifting rock shaft bushing	2	○	○								
156	MG 30A0 460	W483458H02	Feed lifting rock shaft	1	○	○								
157	M9 1603 003	W501009H01	Screw 1/4(24)×16	1	○	○	○	○						
158	MG 30A0 463	W483457H01	Feed lifting rock shaft crank (right)	1	○	○								
159	MG 30B0 384	W480485H01	Feed connecting crank rod	1	○	○	○	○						
160	M9 1551 015	W480471H02	Hinged screw M6 P0 75×24	1	○	○	○	○						
161	MF 60A0 700	W500836H01	Spring for felt stopper	1	○	○	○	○						
162	MF 60A1 740	W500738H01	Felt for feed connecting crank rod	1	○	○	○	○						
163	M9 1606 001	B 504016H01	Set screw 1/4(40)×7	2	○	○	○	○						
164	M9 0325 065	S 591411H05	C-type stop ring	1	○	○	○	○						
165	MG 30A0 760	W483455H01	Feed lifting eccentric	1	○	○								
166	M9 0607 050	S 562131H04	Washer 6	1	○	○	○	○						
167	M9 1572 045	S 542112H01	U-nut 6×0.75	1	○	○	○	○						
168	MG 10B0 763	W461042H01	Bell crank	1	○	○								
169	M9 1210 002	W501247H01	Screw 3/16(28)×10	2	○	○								
170	MG 41B1 572	W502462H01	Spring	1	○	○	○	○						
171	MG 30B0 732	W464020G01	Spring guide bar complete	1	○	○	○	○						
172	MG 30B0 226	W461057H01	Prop up plate	1	○	○	○	○						
173	M9 0301 064	S 584412H03	Spring Pin	2	○	○								
174	M9 1110 002	W500294H01	Screw 11/64(40)×8	3	○	○	○	○						
175	MG 30B1 765	W480467H01	Bell crank guide bracket	1	○	○	○	○						
176	MG 10B0 411	W501534H01	Bell crank guide bracket block	1	○	○	○	○						
177	M9 0507 063	W502457H01	Bell crank guide pin	1	○	○	○	○						
178	M9 1681 015	W480472H01	Hinged screw 1/4(40)×12	1	○	○	○	○						
179	MG 10B0 910	W457552H01	Feed lifting rock shaft link	1	○	○	○	○						
180	MG 30A0 462	W488479H01	Upper feed lifting rock shaft crank	1	○	○								
181	M9 1506 002	W488368H01	Taper pin	1	○	○	○	○						
910	MF	W488478G01	Feed lifting rock shaft complete	1	○	○								

UPPER FEED MECHANISM

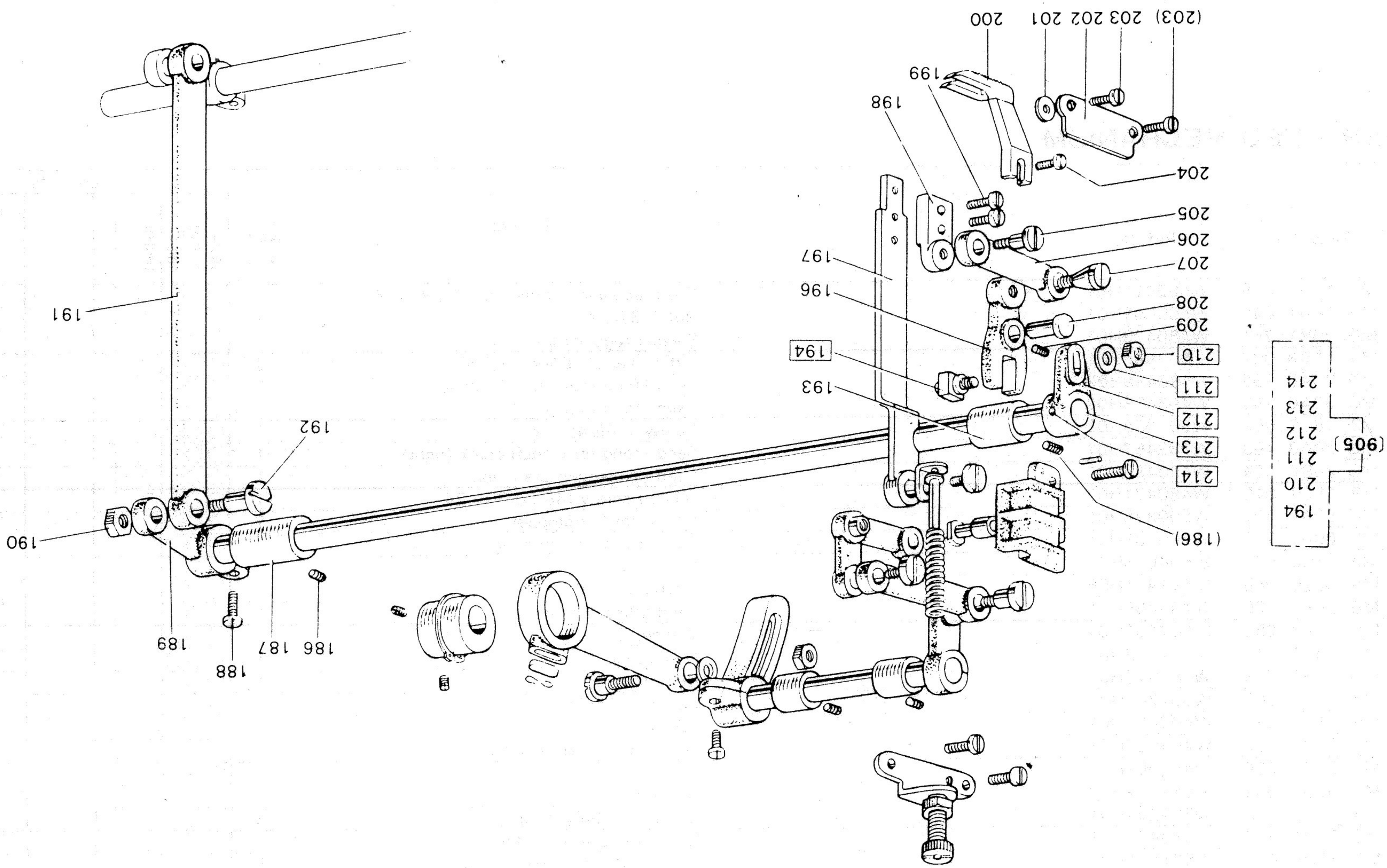

UPPER FEED MECHANISM

Fig. No.	Parts No.	Ref. No.	Description	Amt. Req.	Common Parts																		
					167R	167RB	166R	166RB															
186	M9 1108 001	B 503846H01	Set screw 11/64(40)×5.5	2	○	○	○	○															
187	MG 30B0 287	W466249H01	Feed driving shaft bushing (right)	1	○	○	○	○															
188	M9 1603 003	W501009H01	Screw 1/4(24)×16	1	○	○	○	○															
189	MG 30E0 465	W462666H01	Feed driving rock shaft crank	1	○	○	○	○															
190	M9 1802 045	B 508961H01	Nut 9/32(28)	1	○	○	○	○															
191	MG 30B0 954	W324564H01	Feed drive connecting link	1	○	○	○	○															
192	M9 1803 015	W454870H01	Hinged screw for connecting rod 9/32(28)×26.1	1	○	○	○	○															
193	MG 30B0 285	W457554H01	Feed driving shaft bushing (left)	1	○	○	○	○															
194	MG 30E0 410	W488427G01	Feed connecting sliclk block complete	1	○	○																	
196	MG 30A0 950	W483462H01	Feed connecting rod lever	1	○	○																	
197	MG 30B0 295	W461085H01	Walking foot guide link	1	○	○	○	○															
198	MG 30B2 273	W480470H02	Feed arm	1	○	○	○	○															
199	M9 0910 003	B 509270H01	Screw 9/64(40)×7	2	○	○	○	○															
200	MG 10B0 294	W321338H01	Walking foot	1	○	○	○	○															
201	M9 0414 050	W480469H01	Washer	2	○	○	○	○															
202	MG 30A0 296	W483464H01	Walking foot guide bracket	1	○	○																	
203	M9 1112 002	W501889H01	Screw 11/64(40)×12	2	○	○	○	○															
204	M9 0922 002	W464016H01	Screw 9/64(40)×8	1	○	○	○	○															
205	M9 1681 015	W480472H01	Hinged screw 1/4(40)×12	1	○	○	○	○															
206	MG 30A0 910	W483495H01	Walking foot connecting link	1	○	○																	
207	M9 1601 036	W487003H01	Teper screw 1/4(40)×26	1	○	○																	
208	MG 30A0 530	W483463H01	Hing pin	1	○	○																	
209	M9 1508 001	B 509088H01	Set screw 15/64(28)×8	1	○	○																	
210	M9 1601 045	W501058H01	Nut 1/4(24)	1	○	○	○	○															
211	M9 0617 050	S 562111H01	Washer	1	○	○	○	○															
212	MG 30B0 464	W464053H01	Feed driving rock shaft crank (left)	1	○	○																	
213	MG 30B0 467	W461080H01	Feed driving shaft (upper)	1	○	○																	
214	M9 0401 061	W501209H01	Taper pin	1	○	○																	
905	MG 30E0 467	W346058G01	Feed driving shaft complete	1	○	○																	

LOWER FEED MECHANISM

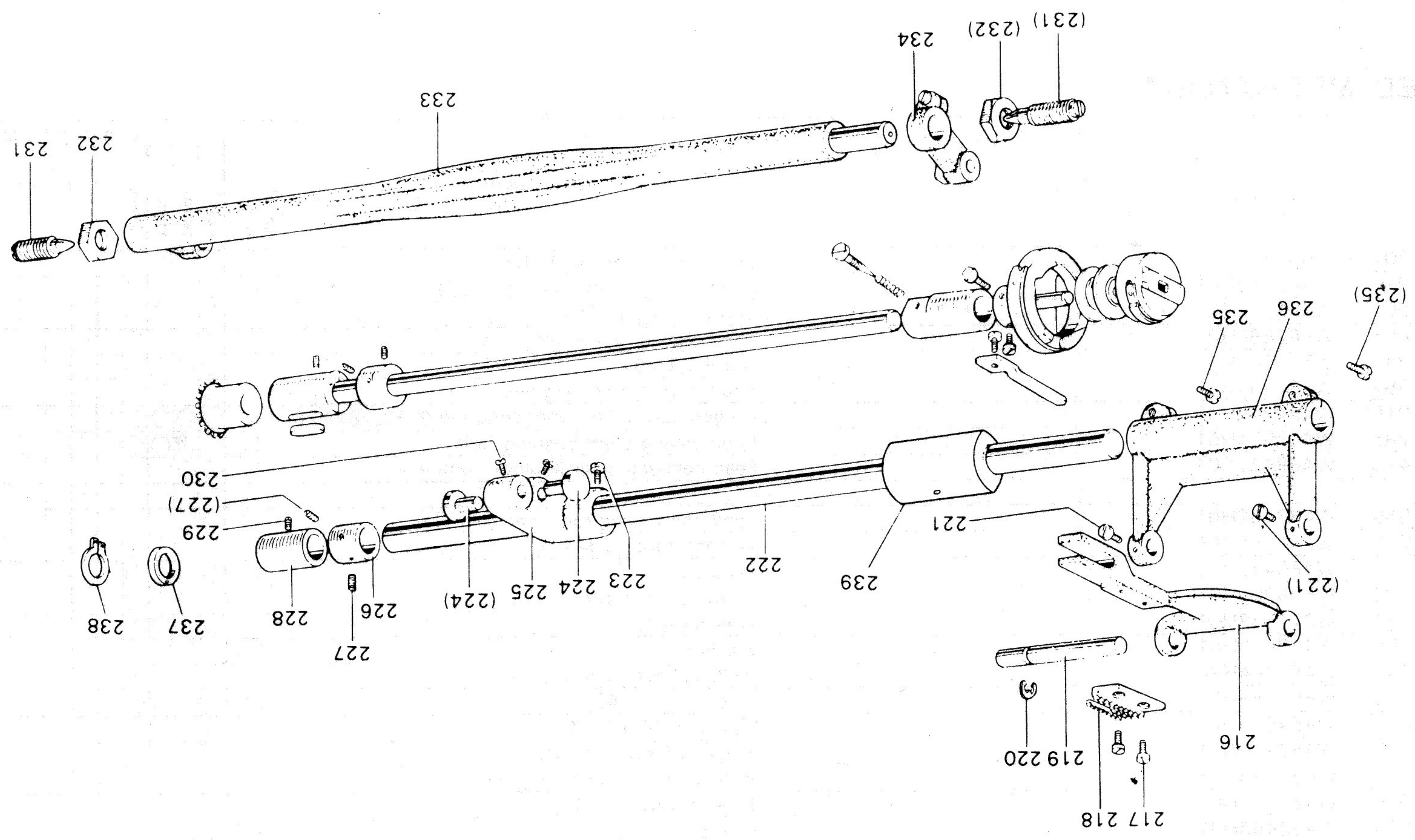

LOWER FEED MECHANISM

Fig.	Parts. No.	Ref. No.	Description	Amt. Req.	Common Parts															
					167R	167RB	166R	166RB												
216	MG 30A0 281	W484831H02	Feed bar	1	○															
	MG 37A0 281	W483498G01	Feed bar	1		○														
217	M9 0806 002	B 508857H01	Screw 1/8(44)×6	2	○	○	○	○												
218	MF 10A0 104	W462604H01	Feed dog	1	○	○	○	○												
219	MG 30A0 283	W483497H01	Feed bar holder stud	1	○	○														
220	M9 0505 065	S 592411H05	E-type spring	1	○	○	○	○												
221	M9 1110 002	W500294H01	Screw 11/64(40)×8	2	○	○	○	○												
222	MG 30A0 491	W488442H01	Feed rock shaft	1	○	○														
223	M9 1603 003	W501009H01	Screw 1/4(24)×16	1	○	○	○	○												
224	M9 0904 060	W502476H02	Pin for feed lifting rock shaft crank	2	○	○	○	○												
225	MG 30B0 306	W480463H01	Feed lifting & rock shaft crank	1	○	○	○	○												
226	MF 70A0 352	W476422H01	Collar	1	○	○														
227	M9 1602 001	W500036H01	Set screw 1/4(40)×4	2	○	○														
228	MG 30A0 285	W483472H01	Feed rock shaft bushing	1	○	○														
229	M9 1513 001	B 509060H01	Set screw 15/64(28)×10	1	○	○	○	○												
230	M9 1516 002	W502945H02	Screw 15/64(28)×8.5	2	○	○														
231	M9 2403 034	W464015H01	Feed lifting rock shaft screw 3/8(28)×35	2	○	○	○	○												
232	M9 2402 045	B 509118H01	Nut 3/8(28)	2	○	○	○	○												
233	MF 60A0 460	W321790H01	Feed lifting rock shaft	1	○	○	○	○												
234	MF 60E0 276	W484828G03	Feed lifting rock shaft crank complete (left)	1	○	○														
235	M9 1203 002	B 509178H01	Screw 3/16(28)×5	2	○	○	○	○												
236	MG 30A0 278	W483499H01	Feed rock shaft crank (left)	1	○	○														
237	M9 3001 052	W502467H01	Feed rock shaft bushing washer	1	○	○	○	○												
238	M9 0315 065	S 591411H15	C-type stop washer	1	○	○														
239	MG 30A1 285	W488434H01	Feed rock shaft bushing	1	○	○														

HOOK SHAFT & ROTATING HOOK MECHANISM

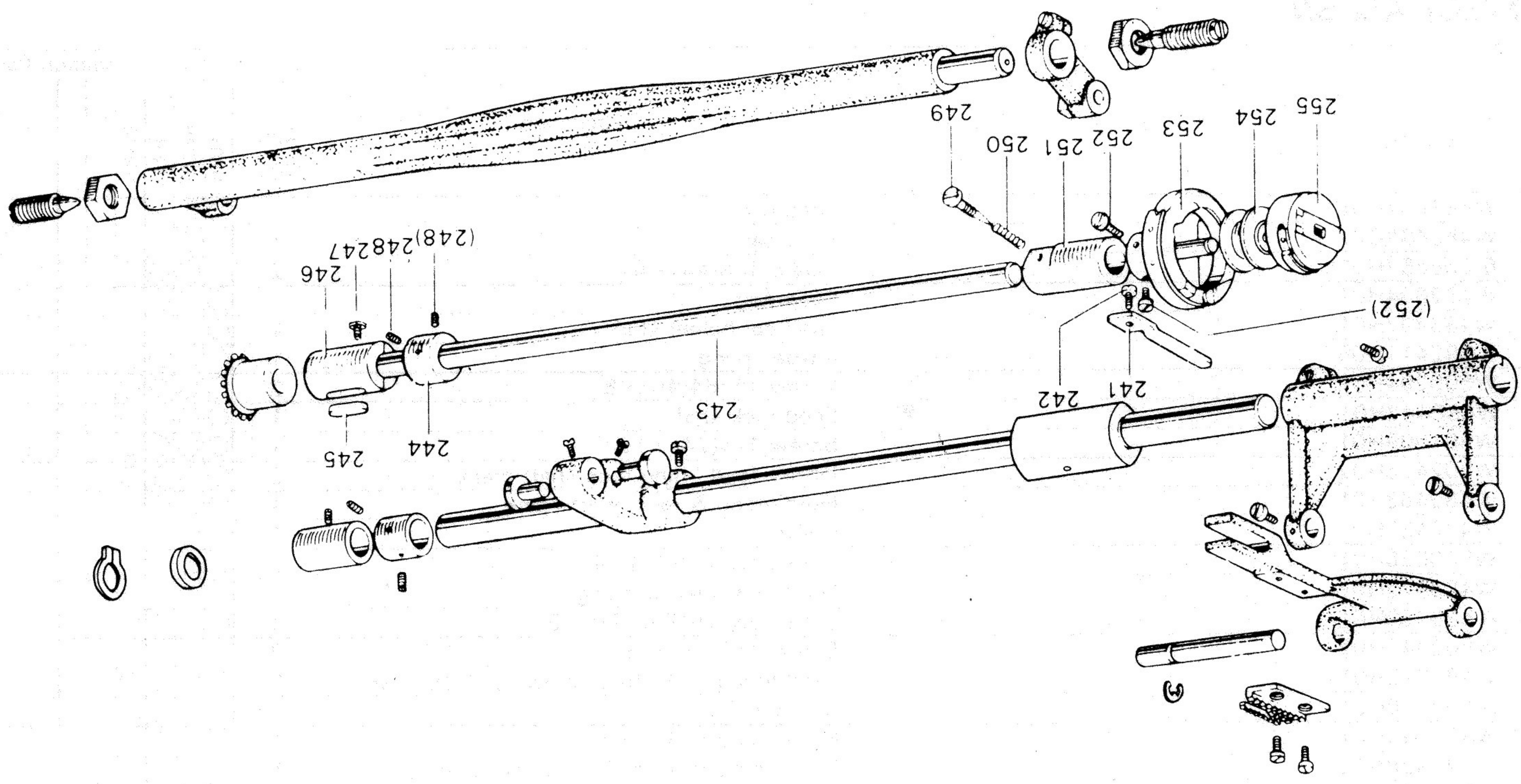

HOOK SHAFT & ROTATING HOOK MECHANISM

Fig No.	Parts No.	Ref. No.	Description	Amt. Req.	Common Parts														
					167R	167RB	166R	166RB											
241	MF 10A0 229	W462633H01	Rotating hook positioner	1	○		○												
	MF 20A0 229	W468837H01	Rotating hook positioner	1		○		○											
242	M9 1118 002	B 509061H01	Screw 11/64(40)×10	1	○	○													
243	MG 30A0 450	W483493H01	Rotating hook shaft	1	○	○													
244	MF 10A0 352	B 422844H01	Collar for rotating hook shaft	1	○	○													
245	MF 60A0 740	W500042H01	Felt	1	○	○	○	○											
246	MG 37B0 452	W462738H01	Rotating hook shaft bushing(right)	1	○	○		○											
247	M9 1117 002	B 503844H01	Screw 11/64(40)×13	1	○	○	○	○											
248	M9 1503 001	B 508971H01	Set screw 15/64(28)×4.5	2	○	○	○	○											
249	M9 0801 006	W487008H01	Screw M3×0.35×9.5	1	○	○													
250	MG 30A0 700	W487009H01	Spring	1	○	○													
251	MG 30A0 451	W349728G01	Rotating hook shaft bushing (left)	1	○	○													
252	M9 1103 002	B 509062H01	Screw 11/64(40)×5	2	○	○	○	○											
	MF 22B0 120	P 975031X01	Rotating hook complete HSL-AN	1	○														
253	MF 25B0 120	P 975032X01	Rotating hook complete HSM-A	1		○													
	MF 10A0 123	W462632H01	Bobbin	1	○		○												
254	MF 25B0 123	W470215H01	Bobbin	1		○		○											
	MF 10E0 125	W461742G01	Bobbin case complete	1	○		○												
255	MF 25E0 125	W473391H01	Bobbin case complete	1		○		○											

OIL LUBRICATION MECHANISM

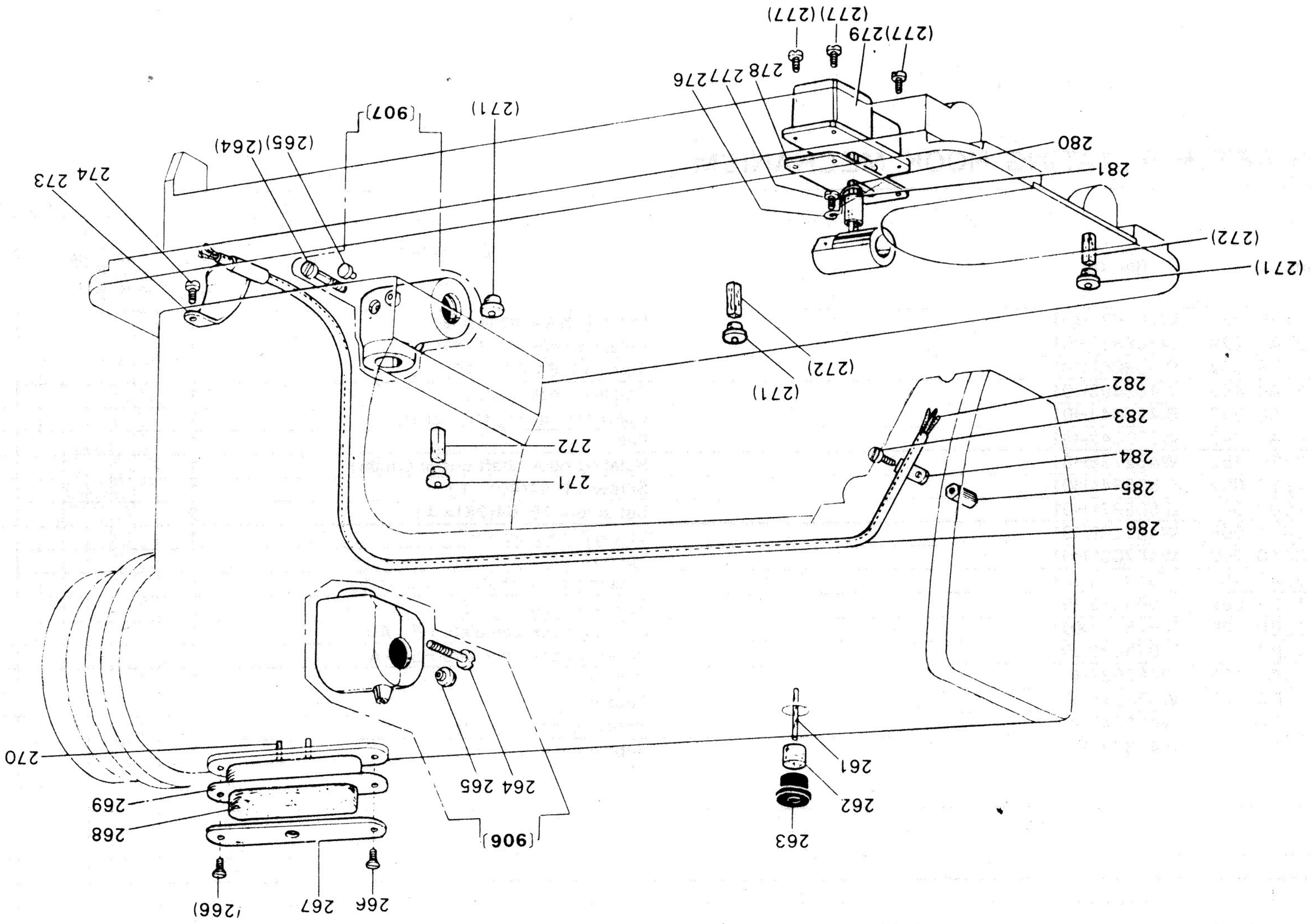

OIL LUBRICATION MECHANISM

Fig. No	Parts. No.	Ref. No.	Description	Amt. Req.	Common Parts														
					167R	167RB	166R	166RB											
261	MF 10E2 148	W464023H01	Oil wick $\phi 2.5 \times 35$	1	○	○	○	○											
262	MF 60A5 740	W500906H01	Felt for oiler	1	○	○	○	○											
263	MG 41B0 742	W471448H01	Cap for oiler	1	○	○	○	○											
264	M9 0501 037	S 512131H41	Screw M5 \times 12	2	○	○	○	○											
265	M9 0570 080	W502078H01	Rubber plug	2	○	○													
906	MF 60E1 711	W482329G02	Arm shaft bevel gear box complete	1	○	○													
266	M9 1109 002	W500511H01	Screw 11/64(40) \times 7	2	○	○													
267	MF 60A0 134	W445619H01	Oil reservoir cover (right)	1	○	○	○	○											
268	MF 60A4 740	W500905H01	Felt for oil reservoir	1	○	○	○	○											
269	MG 30A0 139	W447200H03	Oil reservoir (right)	1	○	○	○	○											
270	MF 10E2 148	W464039H01	Oil wick $\phi 2.5 \times 100$	1	○	○	○	○											
271	MN 10A4 742	W462905H01	Cap for oiler	4	○	○													
272	MG 30A0 740	W462954H03	Felt for oiler 4 \times 5-35	3	○	○													
273	MF 65B0 690	W501200H01	Oil pipe holder	1	○	○	○	○											
274	M9 0920 002	W501523H01	Screw 9/64(40) \times 6.5	1	○	○	○	○											
907	MG 41E0 712	W481406G01	Hook shaft bevel gear box complete	1	○	○	○	○											
276	MG 42A0 689	W487120H01	Pipe holder	1	○														
	MG 43A0 689	W487120H02	Pipe holder	1		○													
277	M9 1101 004	W466810H01	Screw 11/64(40) \times 8	5	○	○													
278	MG 42A1 691	W483469H02	Gasket for oil reservoir	1	○	○													
279	MG 30A1 139	W483470H01	Oil reservoir	1	○	○													
280	MN 10A5 740	W462954H01	Felt	1	○	○													
281	MG 42A1 731	W462995H03	Oil pipe 6 \times 8-15	1	○	○													
282		W464027H02	Wool yarn	1	○	○													
283	M9 1104 003	B 509264H01	Screw 11/64(40) \times 12	1	○	○	○	○											
284	MF 10A0 689	W444230H01	Pipe holder	1	○	○	○	○											
285	M9 1102 045	W501097H01	Nut 11/64(40)	1	○	○	○	○											
286	MF 70A0 731	W482323H01	Oil pipe $\phi 3 \times \phi 4 2 \times 580$	1	○	○													

ACCESSORY BOX & ACCESSORIES

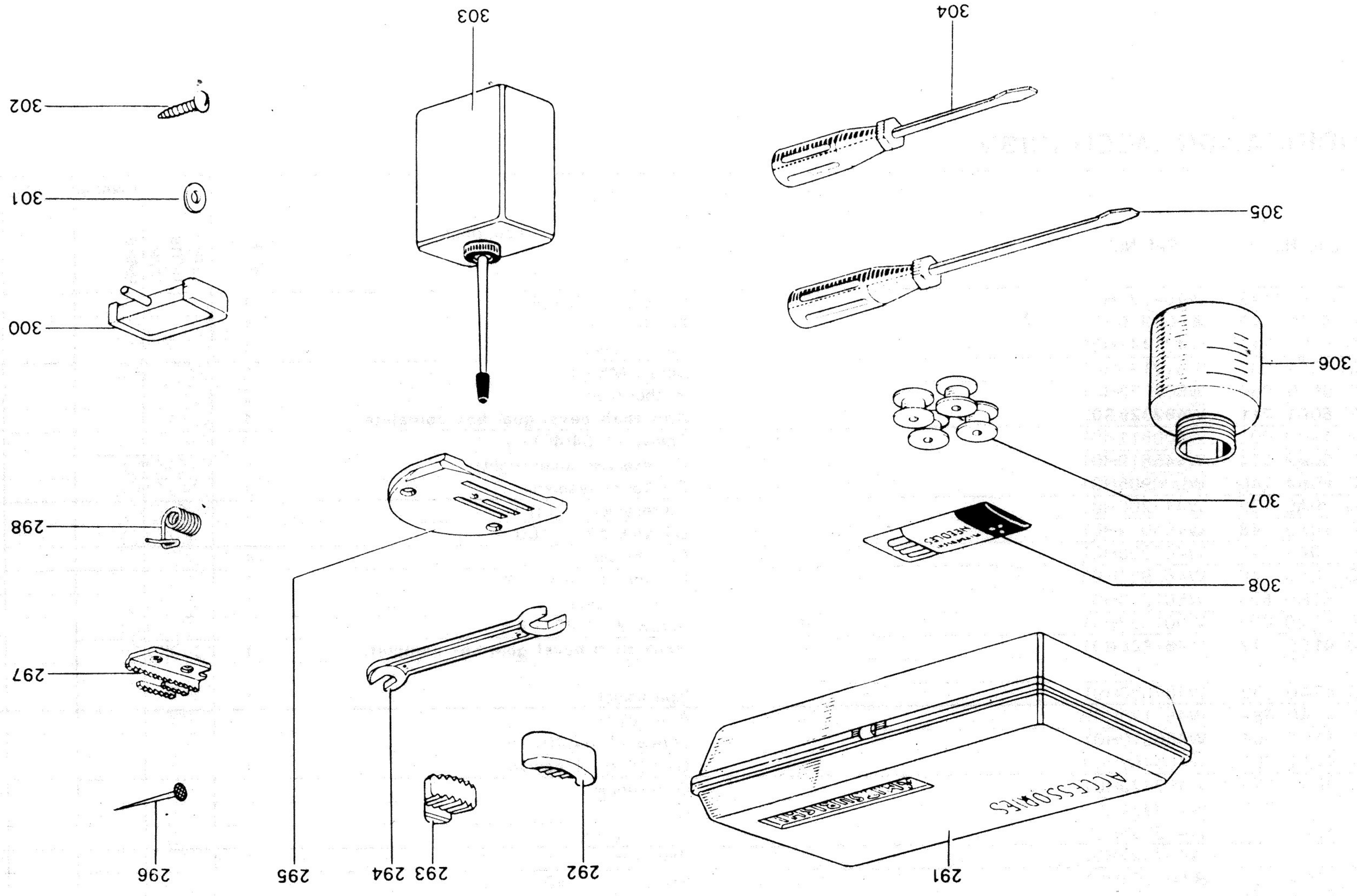

ACCESSORY BOX & ACCESSORIES

Fig. No.	Parts. No.	Ref. No.	Description	Amt. Req.	Common Parts																		
					167R	167RB	166R	166RB															
291	MF 60A0 749	P 833000X01	Accessory box	1	<input type="checkbox"/>	<input type="checkbox"/>	<input type="checkbox"/>	<input type="checkbox"/>															
292	MG 40B0 419	W481654H01	Vibration preventing rubber	2	<input type="checkbox"/>	<input type="checkbox"/>																	
293	MG 40B1 419	W481655H01	Vibration preventing rubber	2	<input type="checkbox"/>	<input type="checkbox"/>																	
294	MM 10A1 101	B 422776H01	Spanner	1	<input type="checkbox"/>	<input type="checkbox"/>	<input type="checkbox"/>	<input type="checkbox"/>															
295	MF 26B0 101	W322721H01	Needle plate (B-2.6) (7mm)	1	<input type="checkbox"/>	<input type="checkbox"/>	<input type="checkbox"/>	<input type="checkbox"/>															
296		S 817001H12	Nail N25	10	<input type="checkbox"/>	<input type="checkbox"/>	<input type="checkbox"/>	<input type="checkbox"/>															
297	MF 10A0 104	W462604H01	Feed dog	1	<input type="checkbox"/>	<input type="checkbox"/>	<input type="checkbox"/>	<input type="checkbox"/>															
298	MF 83A0 187	W486346H02	Thread take-up spring	1	<input type="checkbox"/>	<input type="checkbox"/>																	
299	MF 70A0 560	W467239H02	Hinge rod	2	<input type="checkbox"/>	<input type="checkbox"/>																	
300	MF 70A2 419	W476424H02	Vibration preventing rubber for hinge rod	2	<input type="checkbox"/>	<input type="checkbox"/>																	
301	M9 0607 050	S 562131H04	Washer 6	2	<input type="checkbox"/>	<input type="checkbox"/>	<input type="checkbox"/>	<input type="checkbox"/>															
302	M9 0401 041	S 519132H01	Screw 4.5x20	2	<input type="checkbox"/>	<input type="checkbox"/>	<input type="checkbox"/>	<input type="checkbox"/>															
303	MF 60A0 137	P 831001X01	Oil with Oiler	1	<input type="checkbox"/>	<input type="checkbox"/>	<input type="checkbox"/>	<input type="checkbox"/>															
304	MB 02A1 608	P 842002X01	Screw driver (Small)	1	<input type="checkbox"/>	<input type="checkbox"/>	<input type="checkbox"/>	<input type="checkbox"/>															
305	MB 02A0 608	P 842003X01	Screw driver (middle)	1	<input type="checkbox"/>	<input type="checkbox"/>	<input type="checkbox"/>	<input type="checkbox"/>															
306	MN 10A0 130	W346040H01	Oil pot	1	<input type="checkbox"/>	<input type="checkbox"/>																	
307	MF 10A0 123	W462632H01	Bobbin	4	<input type="checkbox"/>		<input type="checkbox"/>																
	MF 25B0 123	W470215H01	Bobbin	4		<input type="checkbox"/>		<input type="checkbox"/>															
308	MF 83A0 128	S 970002H03	Needle DBx17 #22	4	<input type="checkbox"/>																		
	MG 37A0 128	S 970005H07		4		<input type="checkbox"/>																	

OIL PAN & OTHER ACCESSORIES

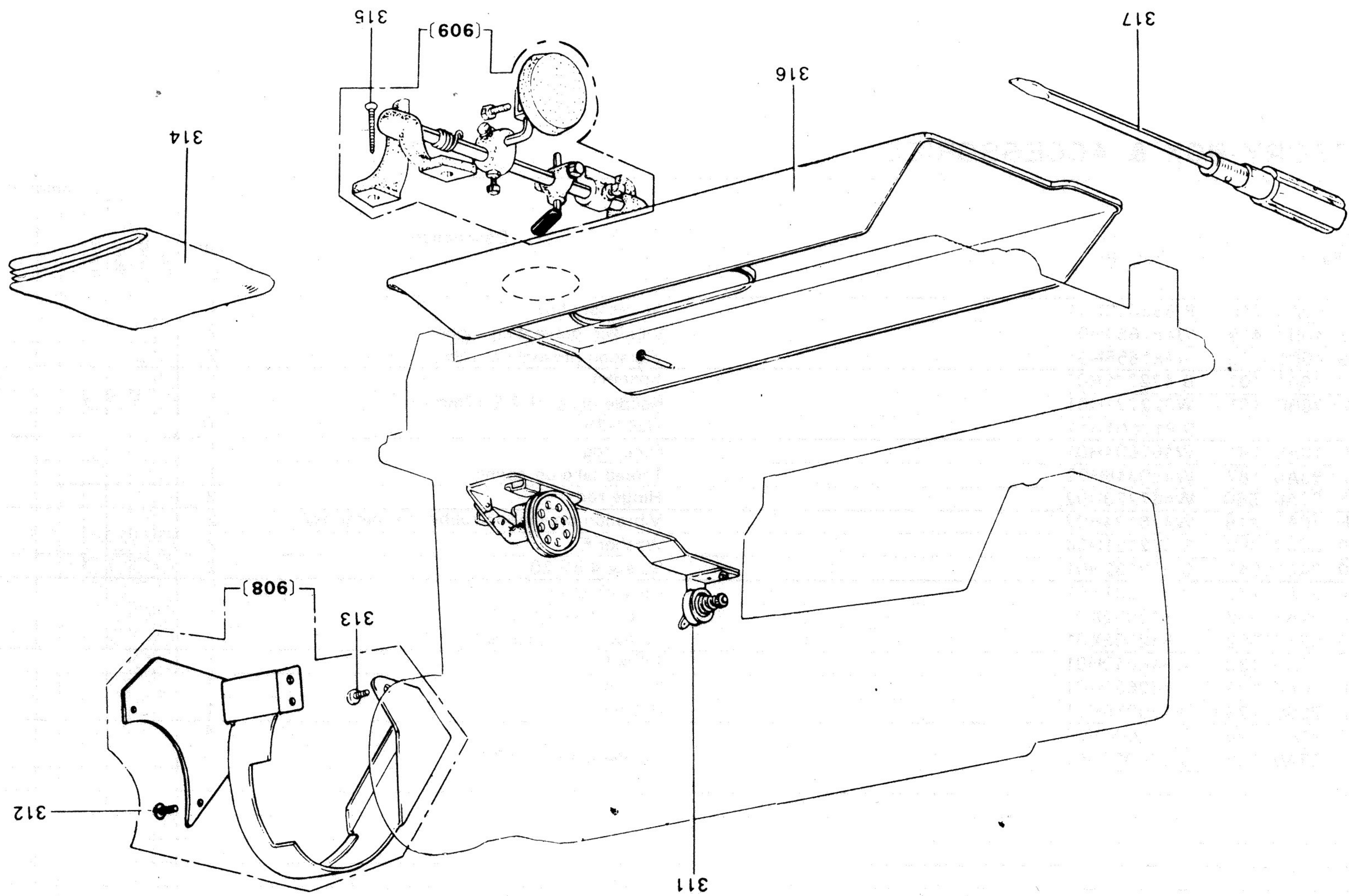

OIL PAN & OTHER ACCESSORIES

Fig. No.	Parts. No	Ref. No.	Description	Amt. Req.	Common Parts															
					167R	167RB	166R	166RB												
311	MF 20E0 190	P 992002X01	Bobbin winder complete	1	<input type="checkbox"/>	<input type="checkbox"/>	<input type="checkbox"/>	<input type="checkbox"/>												
	MF 67E0 190	P 992004X01	Bobbin winder complete	1	<input type="checkbox"/>	<input type="checkbox"/>	<input type="checkbox"/>	<input type="checkbox"/>												
312	M9 1101 004	W466810H01	Screw 11/64(40)×8	3	<input type="checkbox"/>	<input type="checkbox"/>	<input type="checkbox"/>	<input type="checkbox"/>												
908	MF 20E0 776	W341683G01		1	<input type="checkbox"/>	<input type="checkbox"/>	<input type="checkbox"/>	<input type="checkbox"/>												
	MV 02E0 776	W338205G01		1	<input type="checkbox"/>	<input type="checkbox"/>	<input type="checkbox"/>	<input type="checkbox"/>												
313	M9 1506 004	W467868H02	Screw 11/64(28)×8	1	<input type="checkbox"/>	<input type="checkbox"/>	<input type="checkbox"/>	<input type="checkbox"/>												
314	MF 60A0 734	W220627H02	Vinyl covor	1	<input type="checkbox"/>	<input type="checkbox"/>	<input type="checkbox"/>	<input type="checkbox"/>												
315	M9 0401 040	S 519131H04	Screw 4.5×32	4	<input type="checkbox"/>	<input type="checkbox"/>	<input type="checkbox"/>	<input type="checkbox"/>												
909	MF 60E1 727		Knee lifter complete	1	<input type="checkbox"/>	<input type="checkbox"/>	<input type="checkbox"/>	<input type="checkbox"/>												
316	MG 42E0 131	W344933G02	Oil pan	1	<input type="checkbox"/>	<input type="checkbox"/>	<input type="checkbox"/>	<input type="checkbox"/>												
317	MF 60A0 608	W319408H01	Screw drive (large)	1	<input type="checkbox"/>	<input type="checkbox"/>	<input type="checkbox"/>	<input type="checkbox"/>												

MEMORANDUM FOR THE RECORD

MEMO

MEMO



1334